

**Interconnecting any GPS Engine & Temex Smart SRO Rubidium SynClock+® Engine**

**Interconnecting any GPS Engine & Temex Smart SRO-100 Rubidium SynClock+® Engine for Seamless OEM System Integration**

**SmarTiming+™ Technology**  
INSIDE

Contents	
Introduction.....	1
Simple Interconnection Schematic.....	2
Smart Interconnection Schematic.....	3

**Introduction**

At power on or after a Reset, the SRO SynClock+® engine is able to send out on the serial communication port some commands to configure a GPS receiver.

This document shows the 2 basic connectivity schematics. To monitor the GPS or SynClock+® a serial connection with a PC is included. This is only needed for initial tuning. Once it's done, this connection is no longer needed. Thus it is possible to build up an autonomous GPS tracking system.

Please note that to make the SynClock+® tests simple, it is more efficient to order a GDK (GPS SynClock+® Designer Kit) at Temex Time.

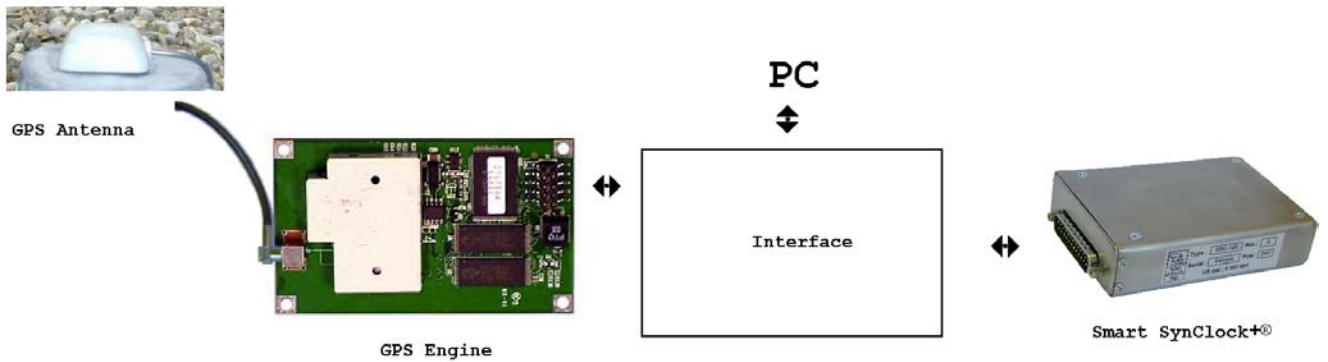

**Figure 1 – GPS, SynClock+® & PC Interconnection**

### Simple Interconnection Schematic

Figure 2 illustrates the PC interconnection interface, which allows communication to the Smart SyncClock+®, but not to the GPS. After the power on or after a reset, the SyncClock+® can send out some commands to configure the GPS receiver. The pin diagram of the GPS connector showed below corresponds to Motorola OnCore and Navman Jupiter products. For the SyncClock+® software setup, please refer to the GDK-1 Designer Kit User Manual on the Temex Time website.

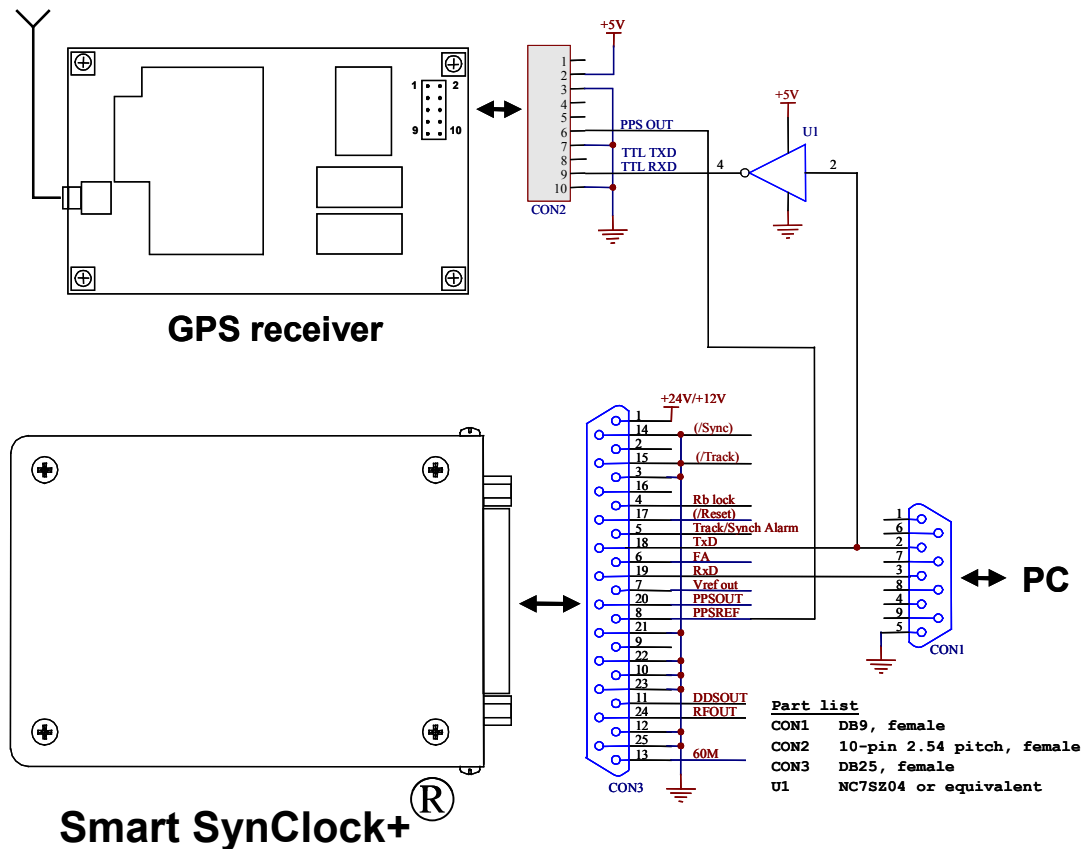

Figure 2 – Simple GPS, SRO SyncClock & PC Interface

### Smart Interconnection Schematic

Figure 3 illustrates the PC interconnection interface, which allows communication to both the Smart SynClock+® and the GPS. After the power on or after a reset, the SynClock+® can send out some commands to configure a GPS receiver. The pin diagram of the GPS connector showed below corresponds to Motorola OnCore and Navman Jupiter products. For the SynClock+® software setup, please refer to the GDK-1 Designer Kit User Manual on the Temex Time website. To monitor the GPS receiver, a software program is provided by the GPS vendor, if needed.

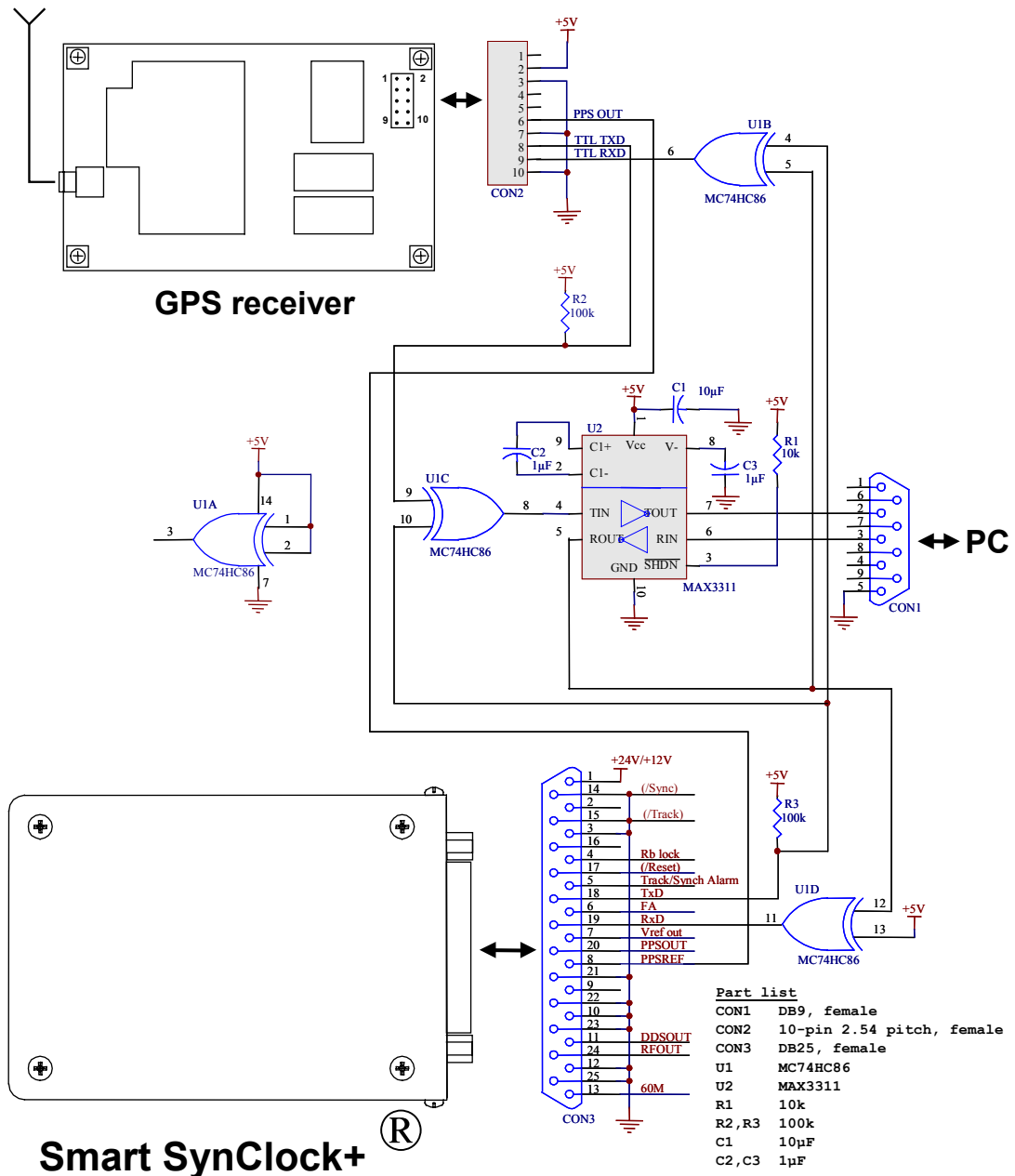

Figure 2 – Simple GPS, SRO SynClock & PC Interface